

Quick Connectors Inc.

Concentric Well Data Sheet

P5000 (Model 1) Penetration Systems

Company Name	
Employee Name	
Date	
Customer	
Country	
Field	
Well Number	
Wellhead Manufacturer	

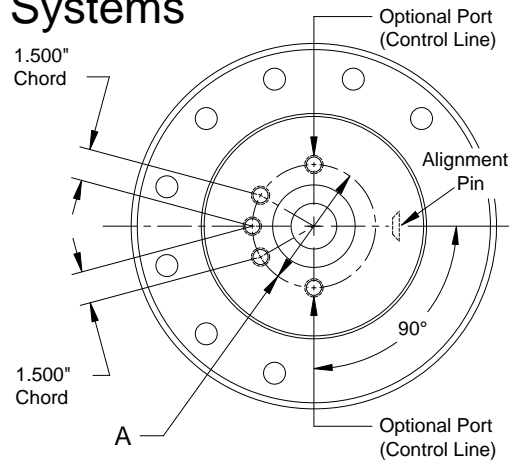

Wellhead Dimensions (Inches)	
A	Penetrator Hole Circle Diameter
D	API Flange Size
E	API Flange Size
F	Thickness Of Adaptor Flange At Studs
G	Maximum Thickness Of Adaptor Flange
H	Distance Between Flanges (12" Min.)
J	Riser O.D.
S	Hanger Length, Distance Between Top And Bottom Ports
T	Penetration Distance
W	Casing Size Nom. I.D.
X	Tubing Size (6 Ft. Pup Joint Req'd.)

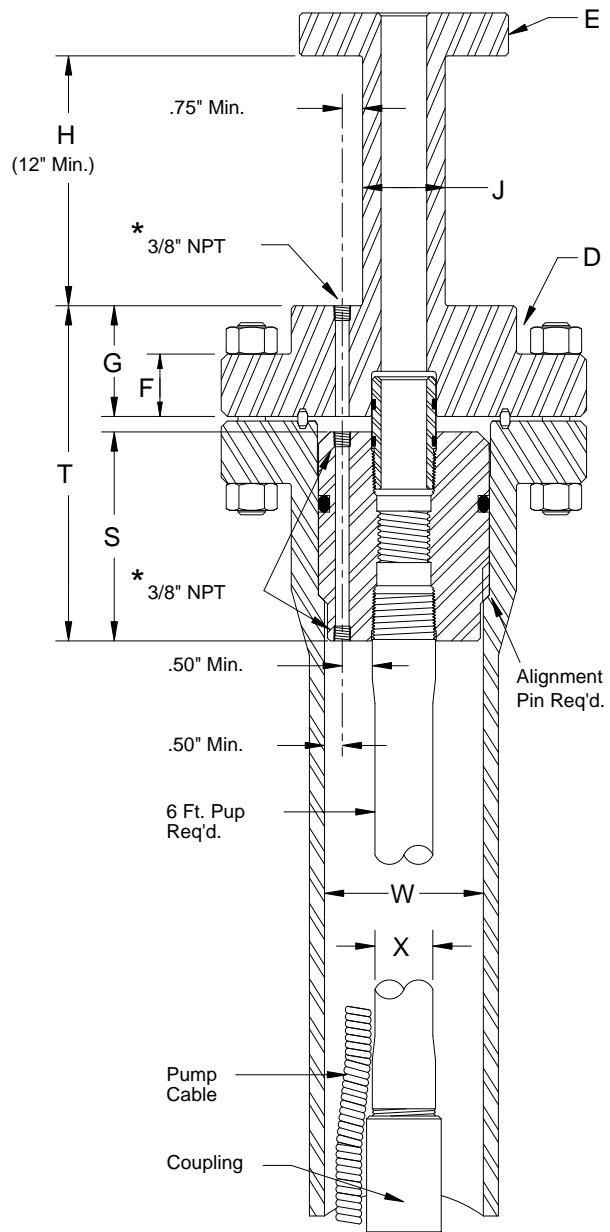

Casing Pressure (psi)	
Flowing Well Temperature (F)	
% H ₂ S	

Pump Cable Description	
Manufacture	
Name	
Part #	
AWG #	
Voltage Rating (kVA)	

* Tap Drill Thru $\varnothing 37/64$ " For All 3 Feed-Thru Ports (For $\varnothing 3/8$ " Stainless Steel Tubes).